

**LASER MEASUREMENT SYSTEM
5526A
OPERATOR'S HANDBOOK SUPPLEMENT
FOR
SINGLE AND/OR DUAL AXIS
PLANE MIRROR MEASUREMENTS
OPTIONS 012/013**

Copyright HEWLETT-PACKARD COMPANY 1973
5301 STEVENS CREEK BLVD., SANTA CLARA, CALIF. 95050

Printed: JAN 1973

Manual Stock No. 05526-90009

PRINTED IN U.S.A.

HEWLETT  PACKARD

GENERAL INFORMATION

INTRODUCTION

This publication is a supplement to the basic 5526A LASER MEASUREMENT SYSTEMS OPERATOR handbook. Put this supplement in the OPERATOR handbook three-ring binder. This supplement provides information on Option 012 and Option 013.

5526A LASER MEASUREMENT SYSTEM AND ITS PUBLICATIONS

Each component of the 5526A system and each standard option are described in separate publications. A current listing of all publications about the 5526A Laser Measurement System is available from:

Hewlett-Packard Company
5301 Stevens Creek Boulevard
Santa Clara, California 95050
Attention: Laser Publications

OPTION 012 PLANE MIRROR CONVERTER

The Hewlett-Packard Model 5526A Option 012 Plane Mirror Converter is an element of the 5526A Laser Measurement System. Option 012 extends the system capability to make linear measurements (single axis) with a plane mirror reflector. Option 012 requires the basic 5500C Laser Head, a modified 5505A Laser Display, Plane Mirror Converter, and the units in Option 010.

The complete list of components required is:

5526A BASIC

| | |
|---|---------------------|
| 1 | 5500C Laser Head |
| 1 | 5505A Laser Display |

OPTION 010

| | |
|---|-------------------------------|
| 1 | 10565B* Remote Interferometer |
| 1 | 10550B* Retroreflector Mount |

OPTION 012

| | |
|---|---------------------------------------|
| 1 | 10581A Plane Mirror Converter |
| 1 | K05-5505A Analog Board |
| 1 | Plane Mirror Reflector (not supplied) |

5505A Laser Display

Because two reflections are inherent in the plane mirror principle, there is optical resolution doubling. A modified 5505A Laser Display is required to restore the read-out of the Laser Display to correct the resolution. The modification consists of replacing the A1 Analog Board with a K05-5505A Analog Board. The modified Analog Board does not double the frequency of the reference and Doppler signal inputs from the Laser Head.

*Includes one 10556A Retroreflector.

OPTION 013 SECOND AXIS ADD-ON

The Hewlett-Packard Model 5526A Option 013 Second Axis Add-on completes the system capability to make linear measurements (dual axis) with plane mirror reflectors. The second axis capability requires the basic 5500C Laser Head and modified 5505A Laser Display, the units in Option 010 Linear Interferometer, the units Option 012 Plane Mirror Converter, and the units in Option 013 Second Axis Add-on.

The complete list of components required is:

5526A BASIC

- 1 5500C Laser Head
- 1 5505 Laser Display

OPTION 010

- 1 10565B Remote Interferometer
- 1 10550B Retroreflector Mount

OPTION 012

- 1 10581A Plane Mirror Converter
- 1 K05-5505A Analog Board

OPTION 013

- 1 5505A Laser Display
- 1 10567 Beam Splitter
- 1 10565B Remote Interferometer
- 1 10581A Plane Mirror Converter
- 1 10556A Retroreflector
- 1 K05-5505A Analog Board
- 2 Plane Mirror Reflectors (not supplied)

NOTE

Distance Change Measurements Only

Only CHANGES in the position of the Plane Mirror Reflector relative to the position of the 10565B Remote Interferometer are measured by the 5526A Laser Measurement System with Options 012/013.

INSTALLATION AND OPERATION

INTRODUCTION

This section provides installation and operating instructions for Option 012 Single Axis and Option 013 Second Axis Add-On Plane Mirror Measurements.

INSTALLATION

When mounting the Plane Mirror Interferometer (illustrated in Figure 1) and the plane mirror reflector, remember that the Laser Measurement System measures any change in the distance between the interferometer and the reflector. It is not significant whether the interferometer moves, the reflector moves, or both move. To ensure system accuracy and proper operation, the components must be correctly mounted and assembled.

Figure 1. Plane Mirror Interferometer

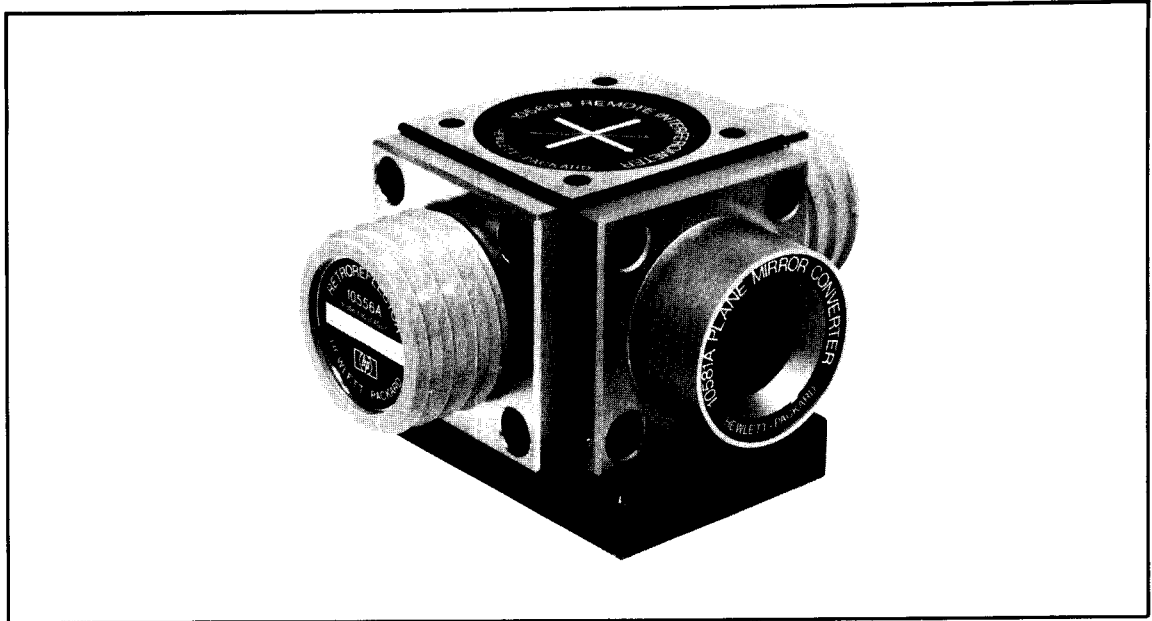

Plane Mirror Interferometer Assembly

The proper assembly procedure for the Plane Mirror Interferometer is detailed in the following steps. This assembly procedure is applicable to both Option 012 and Option 013.

1. Remove the 10556A Retroreflector from the 10550B Retroreflector Mount by removing the four hex head screws.
2. Clean the Remote Interferometer, the Retroreflector, and the Plane Mirror Converter.
3. Gently screw each component in place with four screws each, as shown in Figure 2. Do not tighten the screws more than finger tight.

CAUTION

The Remote Interferometer has precision ground and lapped external surfaces. DO NOT scratch, dent, or, in any way, damage these surfaces.

Figure 2. Retroreflector and Plane Mirror Mounting

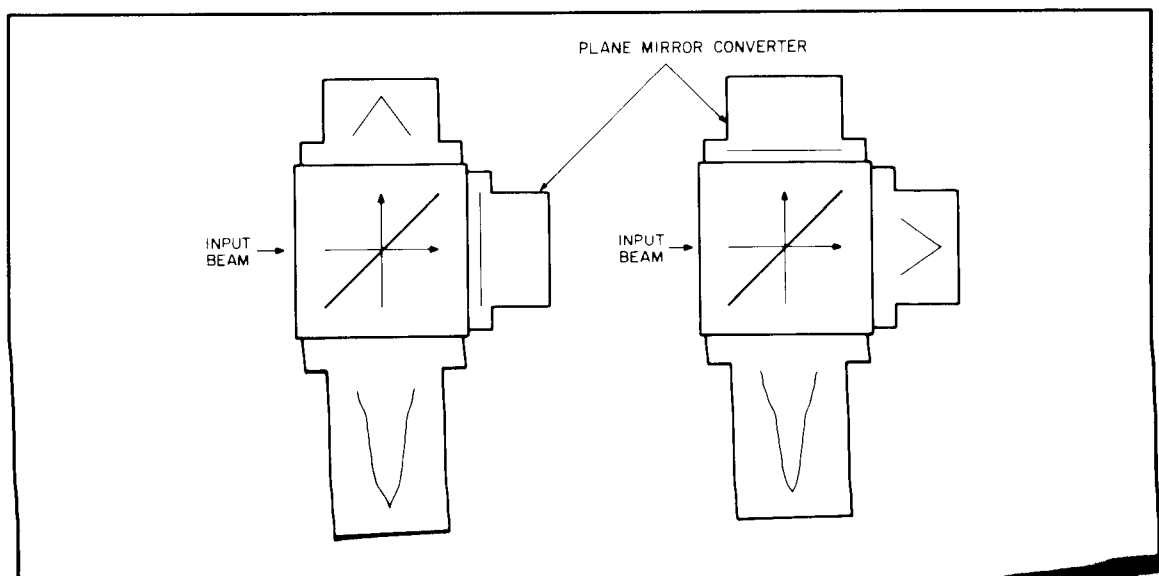

Plane Mirror Interferometer Mounting

The fixturing requirements for the Plane Mirror Interferometer is the same as the Remote Interferometer except that the Plane Mirror Interferometer cannot be mounted inside the 5500C Laser Head. Refer to Option 010 Supplement to the 5526A LASER MEASUREMENT SYSTEM OPERATOR handbook for the proper fixturing procedure.

Plane Mirror Reflector Mounting

The accuracy of the Laser Measurement System can be no better than the mounting of the plane mirror reflector. To maintain system accuracy, the plane mirror reflector must be mounted flat and perpendicular to the plane of measurement. When performing dual axis measurements, the reflectors must also be mounted at 90° to each other.

OPERATION

The 5526A Laser Measurement System can perform either single axis or dual axis plane mirror measurements with Options 012 and 013. The dual axis option is particularly useful for X-Y stage applications. Typical measuring setups for single axis and dual axis measurements are shown in Figures 3 and 4.

Figure 3. Single Axis Measurement

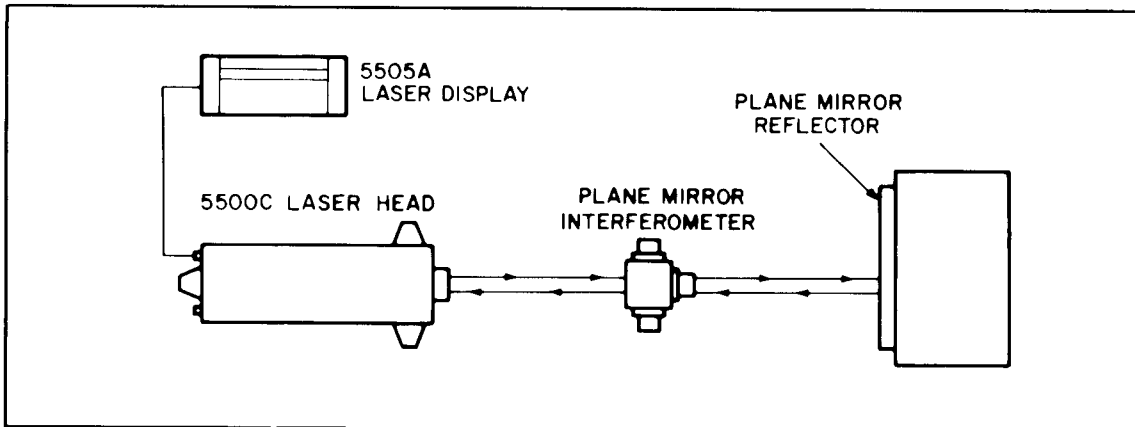
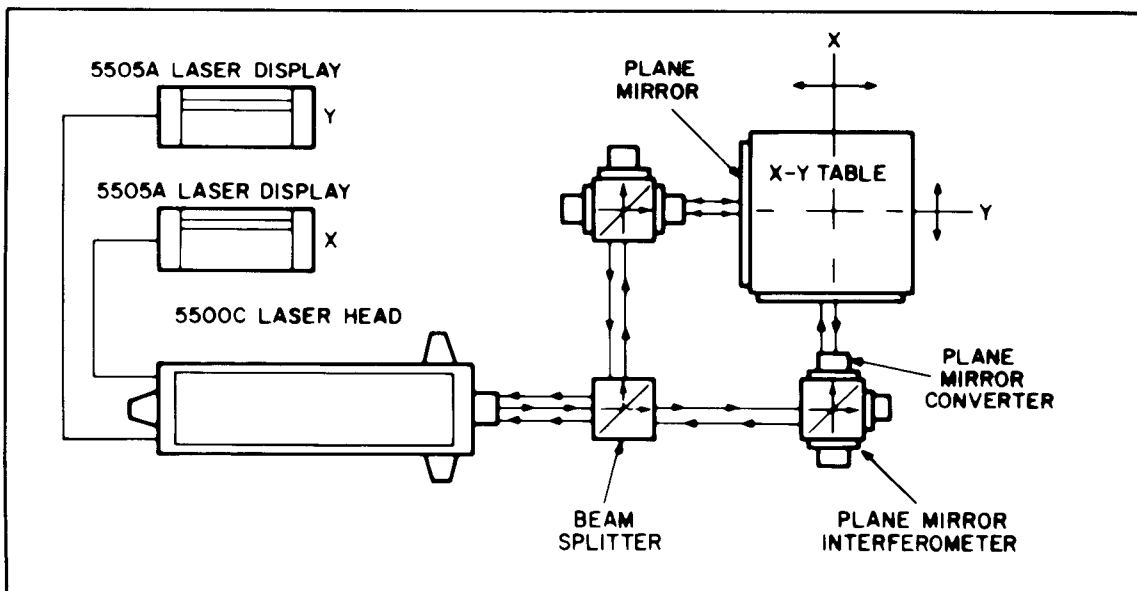

Figure 4. Dual Axis Measurement



When a 5526A Laser Measurement System with either Option 012 or Option 013 is first delivered and set up for use, it should be tested for correct operation. Refer to the 5526A Laser Measurement System Operator handbook for basic system tests. For first operation tests of the 5526A system with either Option 012 or 013, refer to the following paragraphs.

Option 012 Operation Test

1. Set the Laser Head on a flat stable surface. (The 10580A Laser Tripod is recommended to mount the Laser Head.)
2. Put a suitable plane mirror reflector, such as an HP 10557A Turning Mirror, in line with the beam output of the Laser Head.
3. Align the plane mirror reflector so the reflected beam goes back to the laser beam exit port.
4. Put the Plane Mirror Interferometer in line with the beam output of the Laser Head. The Plane Mirror Interferometer position is illustrated in Figure 3.
5. Align the Plane Mirror Interferometer so it's reflected beam goes back to one of the Display A beam return ports.
6. Set the Laser Head aperture control to the small aperture. Slowly tilt or rotate the plane mirror reflector while observing the appropriate Display A beam return port and the laser beam exit port. Verify that the reflected beam moves about the Display A return port and not the laser beam exit port. If the reflected beam moves about the laser beam exit port, it will be very dim.
7. Align the plane mirror reflector until the two reflected beams are superimposed on the same Display A beam return port.
8. Adjust the Plane Mirror Interferometer and plane mirror reflector carefully while watching the BEAM ALIGNMENT meter on the Laser Display for maximum swing to the right in the green region. When the ALIGNMENT meter is near 8, press the RESET button. Observe that flashing stops.
9. With good alignment purposely break the beam with a piece of paper and observe that the RESET light flashes. Again press the RESET button. Press the SMOOTH, X10, and VELOCITY buttons in turn while moving the reflector. Note that the Display indicates the characteristics of each mode. (Refer to the Operator's Handbook.)
10. On the Laser Display press the TUNE \longleftrightarrow switch to the left and the LASER TUNING meter needle should move to the left. Hold the TUNE switch left until the TUNING meter needle moves into the red area, then release the switch. The RESET light should begin flashing about five seconds after the TUNE switch is released.
11. Push the TUNE switch to the right until the LASER TUNING meter needle is near the middle of the green area, and then release the switch. Press the RESET button and its light should stop flashing.
12. PRESS THE TUNE switch to the right, and check that the LASER TUNING meter needle moves to the right. Check that the RESET light begins flashing after the LASER TUNING meter remains in the red area for a few seconds with the TUNE switch released.
13. Center the LASER TUNING meter needle by holding the TUNE switch in the direction the meter needle should go. Press the RESET button.
14. Slowly move the plane mirror reflector some known distance straight back from the Plane Mirror Interferometer. Verify that the 5505A Laser Display indicates the correct displacement and not twice the displacement if the K05-5505A Analog Board is incorporated in the Laser Display.

15. Slowly tilt or rotate the plane mirror reflector so the corresponding half of the laser beam begins to miss part of the return port on the Laser Head. Continue to slide the Reflector slowly until the BEAM ALIGNMENT meter needle moves slowly to the left until the needle is in the red area. The RESET light should begin flashing.

Option 013 Operation Test

Interconnection of the Option 013 Two-Axis Laser Measurement System is similar to the Single Axis Option 012 system, but with the added Option 013 units. Connection of the second 5505A Laser Display unit is the same as the first:

1. Determine whether 115 or 120 volt alternating current line power will be used, and on both display units' rear panels set the SELECTOR slide switch so the voltage shown (115 or 230) matches your primary power source.
2. Check that the FUSE receptacles on both Display units contain the correct fuse (as labeled) to match the power source.

NOTE

The rear of the Laser Head has two connectors for two Laser Display unit cables. The connectors are labeled DISPLAY A and DISPLAY B. On the front of the Laser Head the four laser beam return apertures have labels indicating which two apertures are associated with the corresponding Laser Display (A or B).

3. Connect one Laser Display through a cable to the DISPLAY A connector and connect the second Laser Display through a cable to the DISPLAY B connector.

CAUTION

DO NOT connect or disconnect the Laser Head-to-Laser Display cables when a power cable is connected to the Laser Display. The Laser Head and Laser Display may be damaged if you disregard this CAUTION.

4. Set both Laser Display power switches down (off).
5. Connect power cables to both Laser Displays and to a correct source of power.

CAUTION

Always switch both Laser Display units power to ON simultaneously.

DO NOT switch one Laser Display power ON and wait several moments to switch the second unit ON. (The two Display units may not lock together, and the power supply regulators may malfunction.)

NOTE

In a dual Laser Display system the Laser Display connected to the Laser Head "DISPLAY A" connector will control the Laser Head laser tube turning through the Laser Display "A" Tube switch.

6. Set the Laser Head on a stable surface (the 10580A Laser Tripod is recommended for mounting the Laser Head).

7. Put a suitable plane mirror reflector, such as an HP 10557A Turning Mirror, in line with the beam output of the Laser Head. Take the magnetic template from the 10565B Remote Interferometer and center it on the front of the Turning Mirror.
8. Align the mirror and the Laser Head so the laser beam is directed at the top aperture of the template. Continue to adjust the mirror and the Laser Head to center the reflected beam on the center beam exit aperture of the Laser Head.
9. Put the Beam Splitter in line with the beam output of the Laser Head as shown in Figure 4. The Beam Splitter entrance and exit ports are illustrated in Figure 5.
10. Adjust the Beam Splitter to center the reflected beam on the center beam exit aperture of the Laser Head.

Figure 5. 10567A Beam Splitter

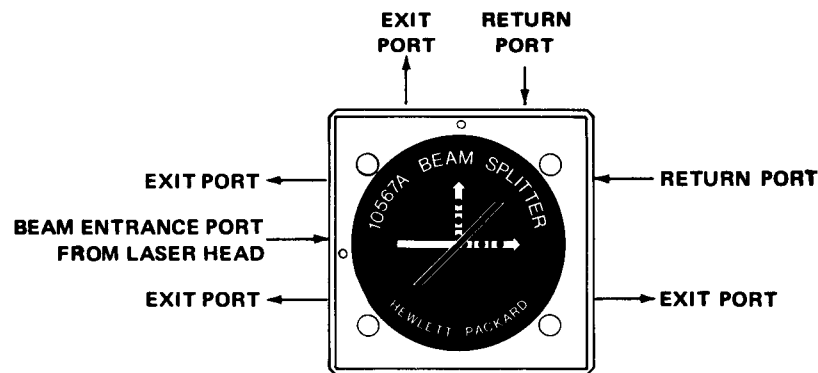

11. Remove the plane mirror reflector.
12. Put one of the Plane Mirror Interferometers along the Y-axis and in line with the beam output of the Beam Splitter. Put the other Plane Mirror Interferometer along the X-axis and in line with the beam output of the Beam Splitter. The Plane Mirror Interferometer positions are illustrated in Figure 4.
13. Align each Plane Mirror Interferometer so its reflected beam is centered in the appropriate Beam Splitter return port (see Figure 5) and Laser Head display return port.

NOTE

To obtain correct alignment, it may be necessary to remove the Remote Interferometer base.

14. Put a plane mirror reflector in line with the beam output of each Plane Mirror Interferometer.
15. Align each plane mirror reflector so its reflected beam is centered in the appropriate Beam Splitter return port and Laser Head display return port.
16. Adjust the Plane Mirror Interferometers and plane mirror reflectors carefully while watching the BEAM ALIGNMENT meter on the appropriate Laser Display for maximum swing to the right in the green region. When the ALIGNMENT meters are near 8, press the RESET buttons. Observe that flashing stops.

17. With good alignment purposely break the beams with a piece of paper and observe that both RESET lights flash. Again press the RESET buttons. Press the SMOOTH, X10, and VELOCITY buttons in turn while moving the mirror. Note that the Display indicates the characteristics of each mode (refer to the Operator's handbook).
18. On the Laser Display (A channel) press the TUNE ← switch to the left and the LASER TUNING meter needle on both Displays should move to the left. Hold the TUNE switch left until the TUNING meter needles move into the red area, then release the switch. Both RESET lights should begin flashing about five seconds after the TUNE switch is released.
19. Push the TUNE switch to the right until the LASER TUNING meter needles are near the middle of the green area, and then release the switch. Press both RESET buttons and the lights should stop flashing.
20. Press the TUNE switch to the right and check that both LASER TUNING meter needles move to the right. Check that both RESET lights begin flashing after the LASER TUNING meter remains in the red area for a few seconds with the TUNE switch released.
21. Center the LASER TUNING meter needles by holding the TUNE switch in the direction the meter needle should go. Press the RESET buttons.
22. Slowly move each reflector, in turn, some known distance straight back from the Plane Mirror Interferometer. Verify that each Laser Display indicates the correct displacement and not twice the displacement if the K05-5505A Analog Board is incorporated in the Laser Displays.

ALIGNMENT

INTRODUCTION

When using the Plane Mirror Interferometer there are two methods that can be used to align the 5526A Laser Measurement System: visual or autoreflection. The visual alignment method should be used only when performing single axis measurements while the autoreflection technique is recommended for dual axis applications.

NEAR AND FAR ENDS OF TRAVEL

For this manual the phrases "near end of travel" and "far end of travel" have certain meanings which are defined here as:

"Near end of travel" means the Plane Mirror Interferometer and plane mirror reflector are at the point of measurement where they are nearest to each other.

"Far end of travel" means the Plane Mirror Interferometer and plane mirror reflector are at the point of measurement where they are farthest from each other.

VISUAL ALIGNMENT METHOD

In the visual alignment method, the plane mirror reflector should be positioned perpendicular to the plane of measurement. Then the Laser Head and Plane Mirror Interferometer are adjusted so, at the near and far ends of travel, the reflected laser beam spot stays on the + mark of the selected return port of the Laser Head turret. The complete procedure is described in Option 010 supplement to the 5526A Laser Measurement System Operator's handbook.

AUTOREFLECTION ALIGNMENT METHOD

In the autoreflection alignment method, a plane mirror reflector is mechanically aligned with its reflected surface perpendicular to the measurement line of travel. Then the Laser Head is set up at least 20 inches from the mirror. The Plane Mirror Interferometer and Laser Head are adjusted so the laser beam is autoreflected by the mirror back to the center beam exit port of the Laser Head turret. The complete procedure is described in the following steps:

1. Remove the 10581 A Plane Mirror Converter from both Plane Mirror Interferometers. Mount each interferometer and the Beam Splitter on an interferometer base.
2. Put the Beam Splitter and Plane Mirror Interferometer on a flat surface and approximately parallel to the plane mirror reflector. Position the Laser Head so the laser beam is centered in the laser beam entrance port of the Beam Splitter (see Figure 5). Component position is illustrated in Figure 6.

Figure 6. Autoreflection Alignment

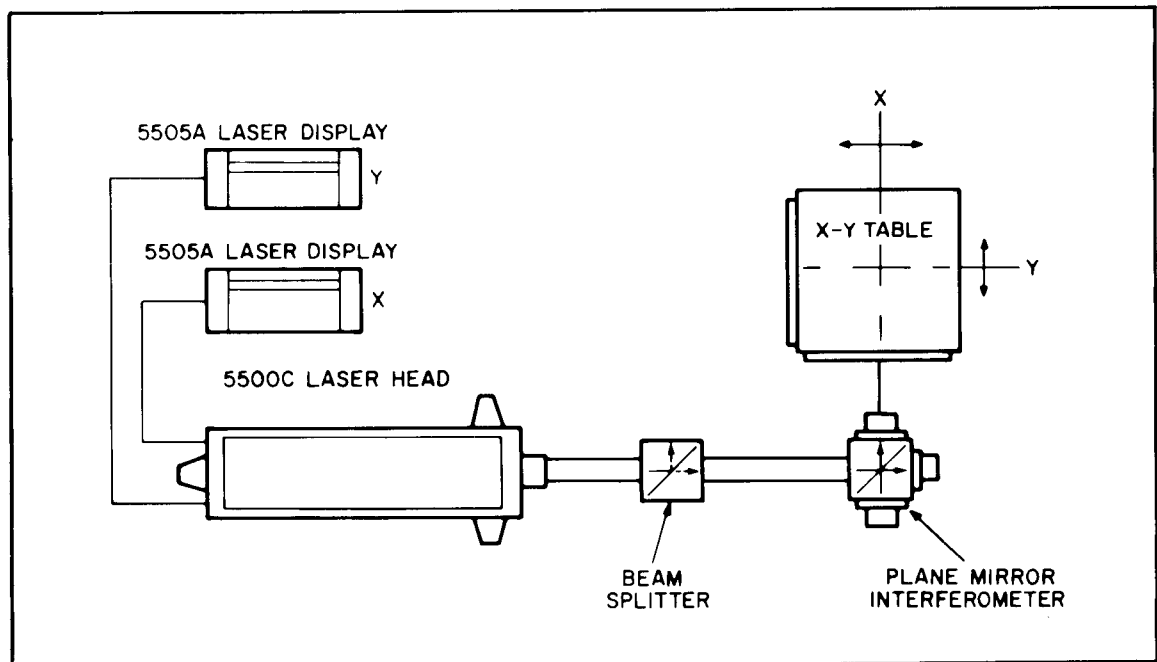

3. Align the Laser Head, Beam Splitter, and Plane Interferometer to center one of the reflected beams on the laser beam exit port of the Laser Head turret. The other reflected beam should be centered on one of the Display A return ports of the Laser Head turret.
4. Securely fasten the Plane Mirror Interferometer. Gently mount the Plane Mirror Converter to the interferometer. Both reflected beams should now be superimposed on the same Display A return port.
5. Place the other Plane Mirror Interferometer approximately parallel to the remaining plane mirror reflector, as shown in Figure 7.
6. Align the Plane Mirror Interferometer and Beam Splitter to center one of the reflected beams on the laser beam exit port of the Laser Head turret. The other reflected beam should be centered on one of the Display B return ports of the Laser Head turret. Ensure that this alignment does not affect the alignment of the first axis.

NOTE

Do not disturb the position of the Laser Head.

Figure 7. Autoreflexion Dual Axis

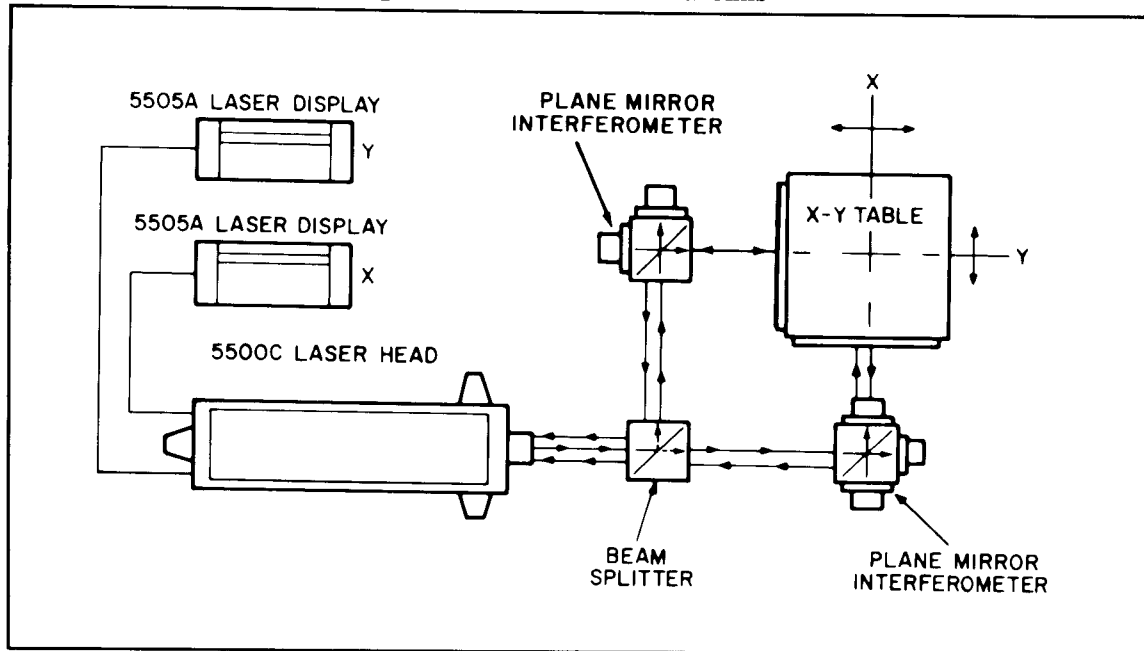

7. Securely fasten the Plane Mirror Interferometer. Gently mount the Plane Mirror Converter to the interferometer. Both reflected beams should now be superimposed on the same Display B return port.
8. If the Beam Splitter and the two Plane Mirror Interferometers are properly aligned with the laser beam, the two BEAM ALIGNMENT meter should indicate in the green area. If not, recheck the system alignment.
9. Momentarily press the RESET on each Laser Display and begin measurements.